

MODÈLE ILLUSTRÉ / ILLUSTRATED MODEL :  
**3023722NCAFR**

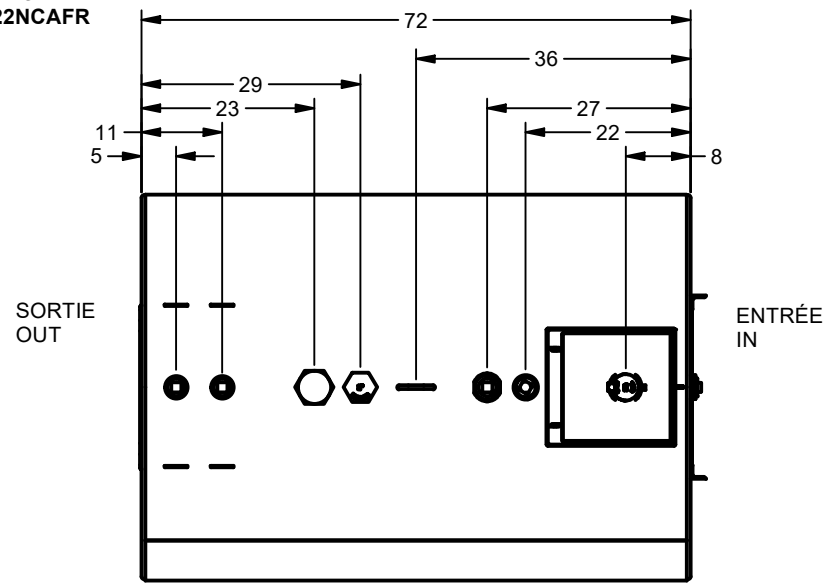

MODÈLES/MODELS	TYPE DE PAROI / WALL TYPE	ÉP. PREMIÈRE PAROI PRIMARY SHELL THK.	ÉP. DEUXIÈME PAROI SECONDARY SHELL THK.	POIDS/WEIGHT (lb)	FINITION	ACCESSOIRES INSTALLÉS INSTALLED ACCESSORIES
3023 722 NCAR	DOUBLE FOND / DOUBLE BOTTOM	2.5mm	2.5mm	560	NC	R
3023 722 NCAFR	DOUBLE FOND / DOUBLE BOTTOM	2.5mm	2.5mm	575	NC	F & R

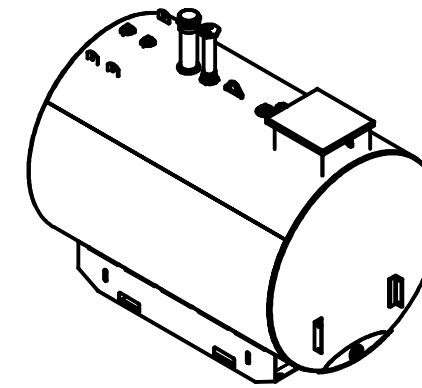

**3023722**  
DOUBLE FOND / DOUBLE BOTTOM

**FINITION ET PEINTURE STANDARD:  
STANDARD FINISHING & PAINT NOTES:**

**NC:**

1. AIR / SAVON TESTÉ À 35 KPa (5 PSI) MAX.
2. FINI INTÉRIEUR : ACIER BRUT, FINI DU MOULIN.
3. FINI EXTÉRIEUR :
  - 3.1 NETTOYÉ AU PHOSPHATE
  - 3.2 APPRÊT EN POUDRE POLYESTER/ÉPOXY, 1.5mil;
  - 3.3 PEINTURE EN POUDRE POLYESTER BLANCHE, 2.5mil.

1. AIR / SOAP TEST TO 35 KPa (5 PSI) MAX.
2. INTERIOR FINISH: BARE STEEL, MILL FINISH
3. EXTERIOR FINISH:
  - 3.1 PHOSPHATE CLEANED
  - 3.2 POLYESTER/EPOXY POWDER COAT PRIMER, 1.5mil;
  - 3.3 WHITE POLYESTER POWDER COAT, 2.5mil.

- ÉVENT D'URGENCE 3" NPT  
3" NPT EMERGENCY VENT
- OUVERTURES 3x 2" NPT  
3x 2" NPT OPENINGS
- SUPPORTS DE BOÎTIER  
PROTECTEUR DE POMPE (ACC. R)  
PUMP CABINET SUPPORTS (ACC. R)
- SIFFLET DE REMPLISSAGE (E525-999)  
FILL VENT ALARM (E525-999)
- OEILLET DE MANUTENTION  
LIFTING LUG
- DISPOSITIF DE DÉTECTION DE FUITE  
LEAK MONITORING DEVICE
- BOUCHON DE REMPLISSAGE 2 1/2" NPT  
2 1/2" NPT FILL CAP

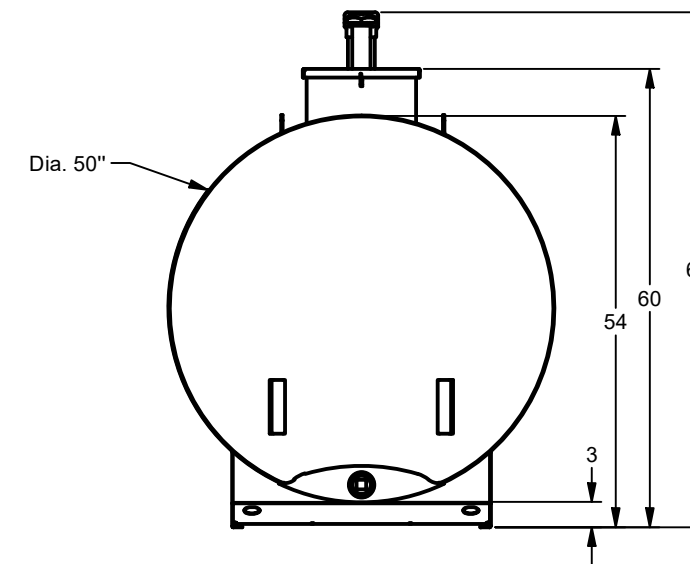
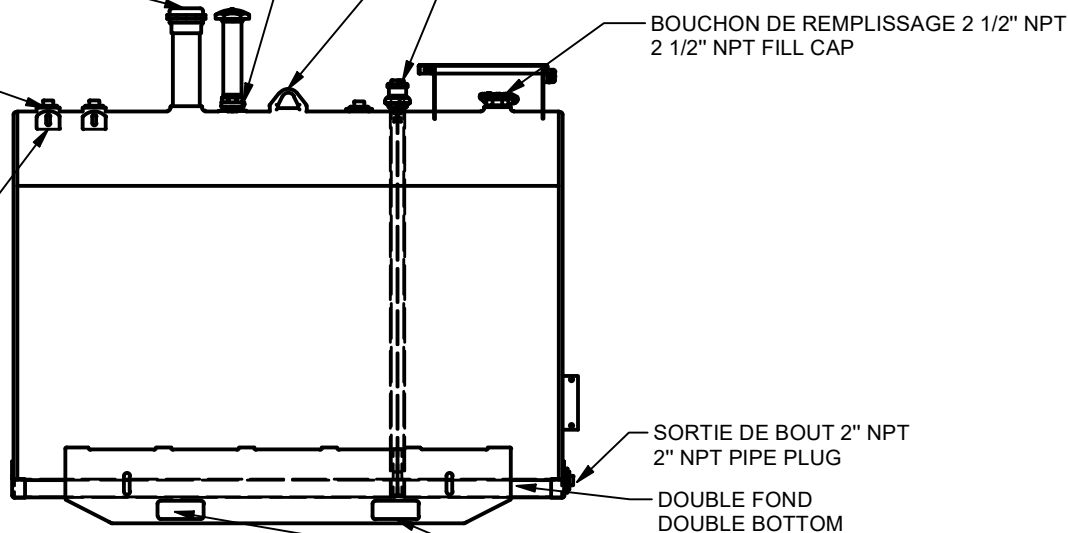

- SORTIE DE BOUT 2" NPT  
2" NPT PIPE PLUG
- DOUBLE FOND  
DOUBLE BOTTOM
- OUVERTURES POUR FOURCHES DE CHARIOT ÉLÉVATEUR  
FORKLIFT OPENING

